



MODEXO



# P-VERA Series Sliding Shower Door

Glass and Hardware

## INSTALLATION MANUAL

Scan for Installation Video

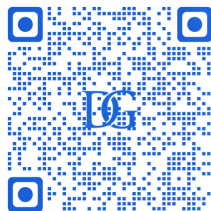

## **IMPORTANT INFORMATION**

Keep this manual and the product code number for future reference. You may need them to order replacement parts.







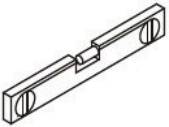

## **GENERAL INSTRUCTIONS**

- Read this manual carefully before starting installation.
- Always wear safety glasses and handle glass panels with care.
- Check that all parts are included before beginning.

## **CARE AND MAINTENANCE**

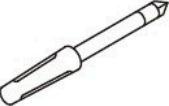
- Clean metal and glass parts with mild soap and water only.
- Do not use scouring pads, abrasive cleaners, or sharp tools.
- Wipe glass panels with a squeegee after each use to help prevent water spots and soap buildup.

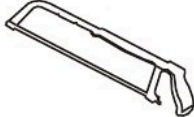
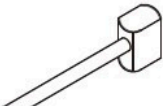
## **TOOLS REQUIRED**









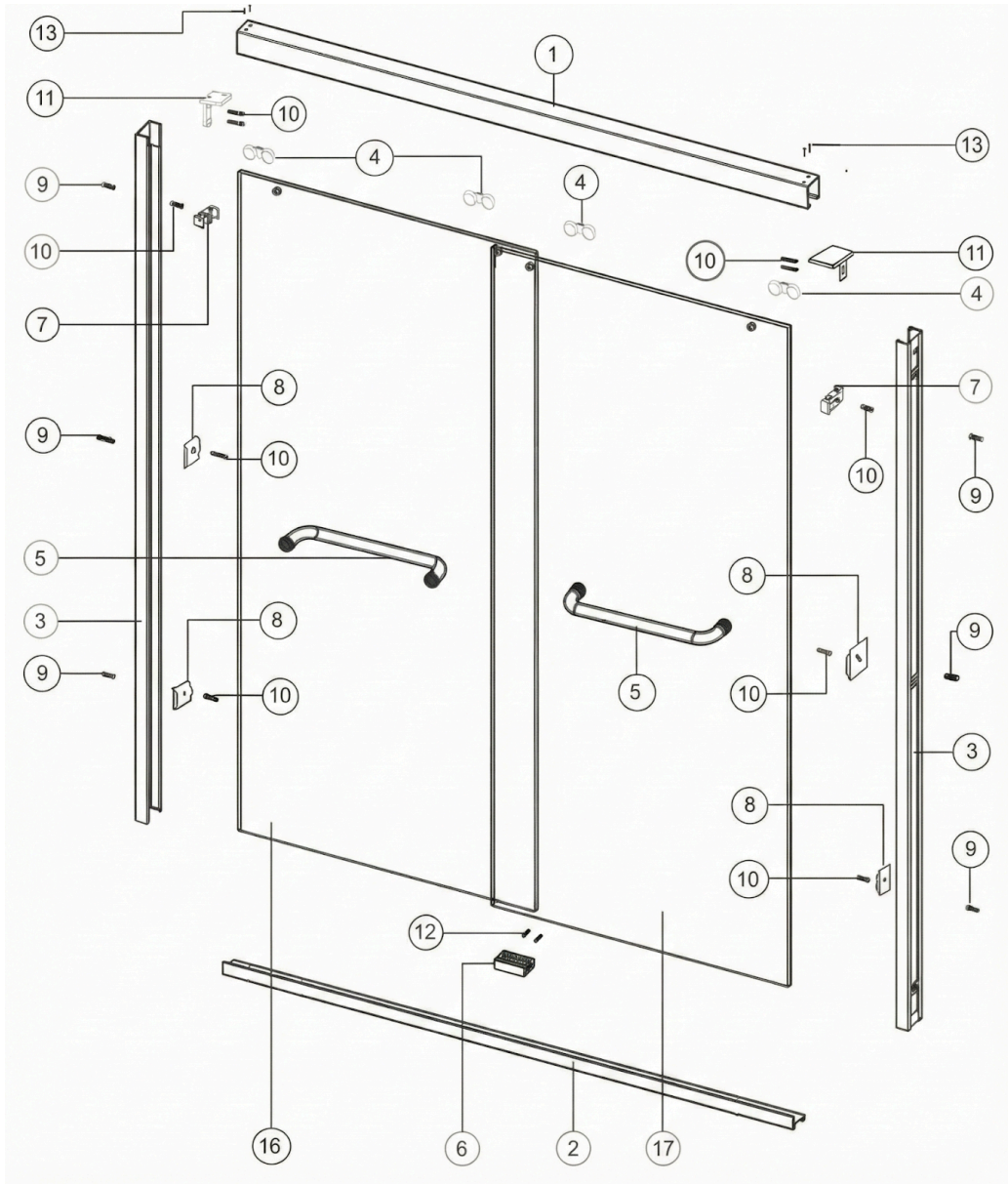









 SPIRIT LEVEL	 TAPE MEASURE	 POWER DRILL	 6mm (1/4") DRILL BIT	 CLEAR MILDEW RESISTANCE SILICONE
 SCREW DRIVER	 PENCIL	 HACKSAW	 MALLET	 SAFETY GLASSES



2 PEOPLE REQUIRED

# PARTS LIST



ITEM	PARTS	DIAGRAM	QTY	ITEM	PARTS	DIAGRAM	QTY
①	HEADER		1	⑨	SCREW ANCHOR		12
②	THRESHOLD		1	⑩	SIDE WALL SCREW		12
③	SIDE FRAME		2	⑪	HEADER BRACKET		2
④	ROLLER		4	⑫	BOTTOM GUIDE SCREW		4
④A	ROLLER ANTI-LIFT		4	⑬	HEADER SCREW		6
⑤	TOWEL BAR		2	⑭	ALLEN TOOL		1
⑥	BOTTOM GUIDE		1	⑮	ALLEN TOOL		1
⑦	SIDE STOPPER		2	⑯	TEMPERED GLASS		1
⑧	SIDE BUMPER		4	⑰	TEMPERED GLASS		1

## STEP 1: PREPARE THE AREA

---

- Make sure the shower base or curb is level.
- Clean all mounting surfaces thoroughly.
- Mark the centerline of the shower base where the enclosure system will be installed.
- Check that both walls are straight and plumb (vertically aligned).

## STEP 2: INSTALL THE SIDE FRAMES

---

- Position the left and right side frames (Item 3) against the walls, centered on the marked centerline.
- Use a spirit level to make sure each side frame (Item 3) is perfectly vertical.
- Mark the screw hole spots on the wall through the pre-drilled holes in the side frames (Item 3).

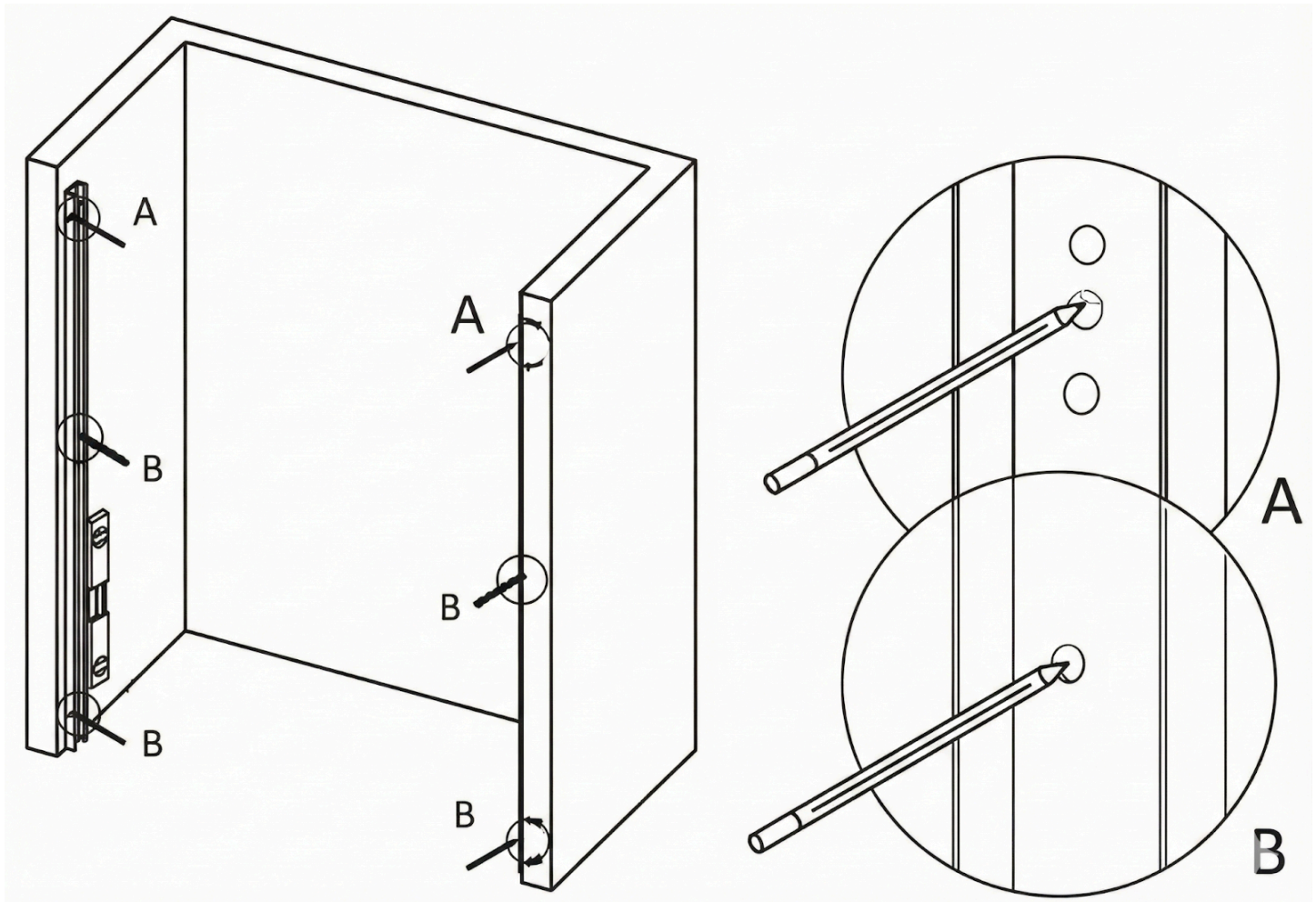

- Drill the holes, then fill each hole with clear silicone and insert the screw anchors (Item 9).
- Secure the side frames (Item 3) along with the header brackets (Item 11), side stoppers (Item 7), and side bumpers (Item 8) using side wall screws (Item 10).

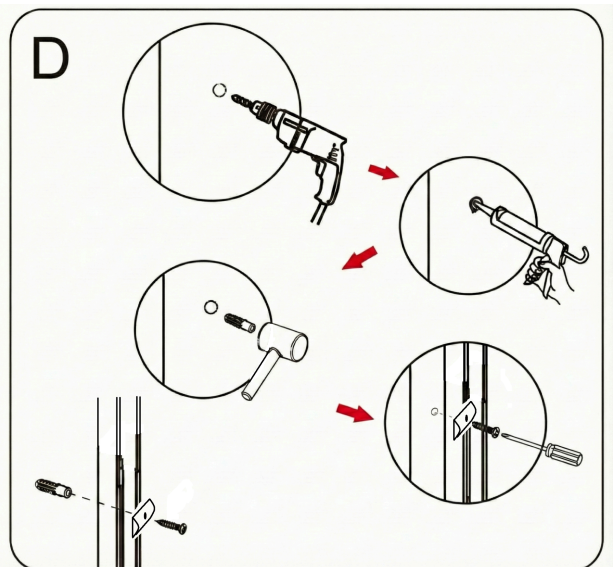
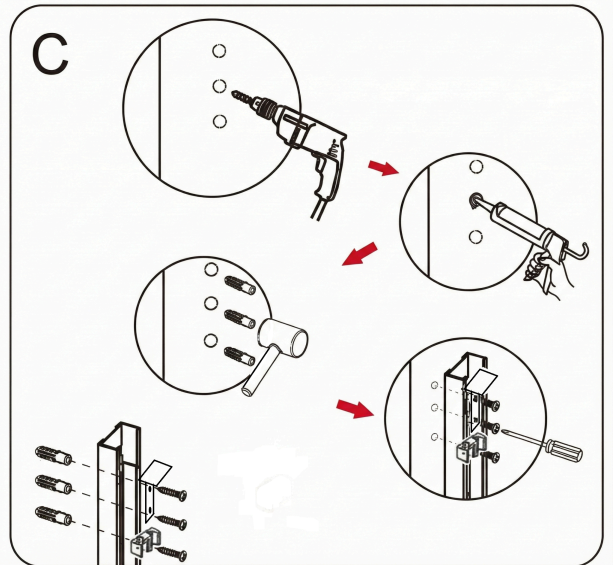
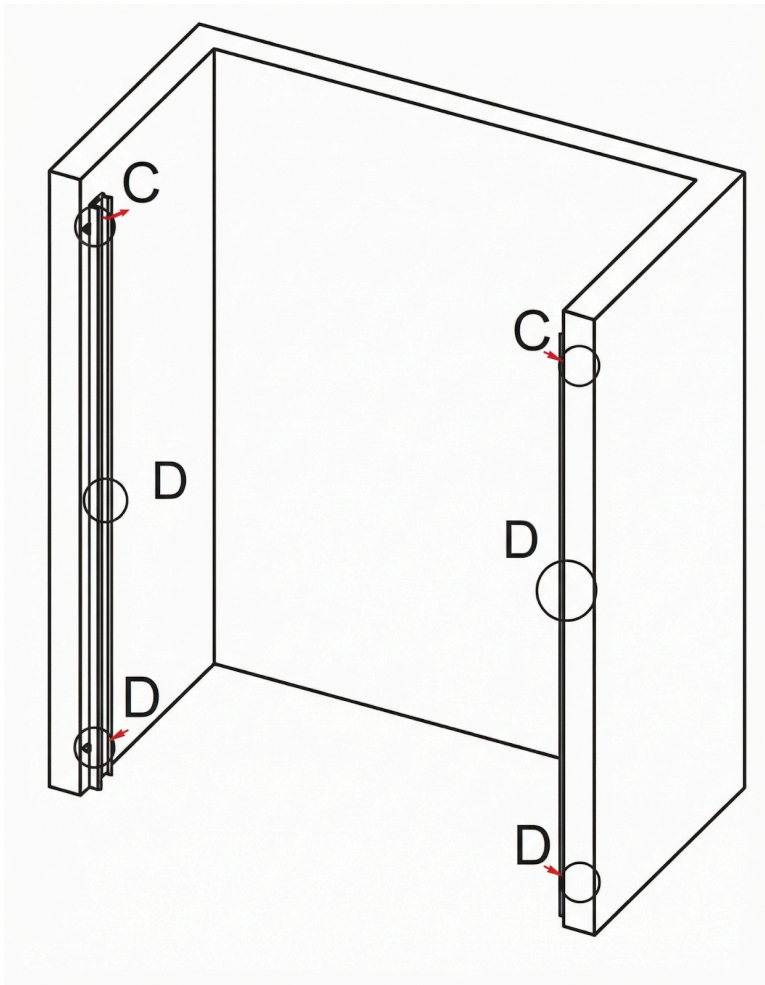

## STEP 3: INSTALL THE THRESHOLD

- Measure and cut (if needed) to fit between the side frames (Item 3). (Shower opening width minus 7/16").
- Apply a bead of clear silicone along the bottom of the threshold (Item 2).
- Insert the left side of the threshold (Item 2) into the left side frame (Item 3), then do the same at the right side, then press it into place.

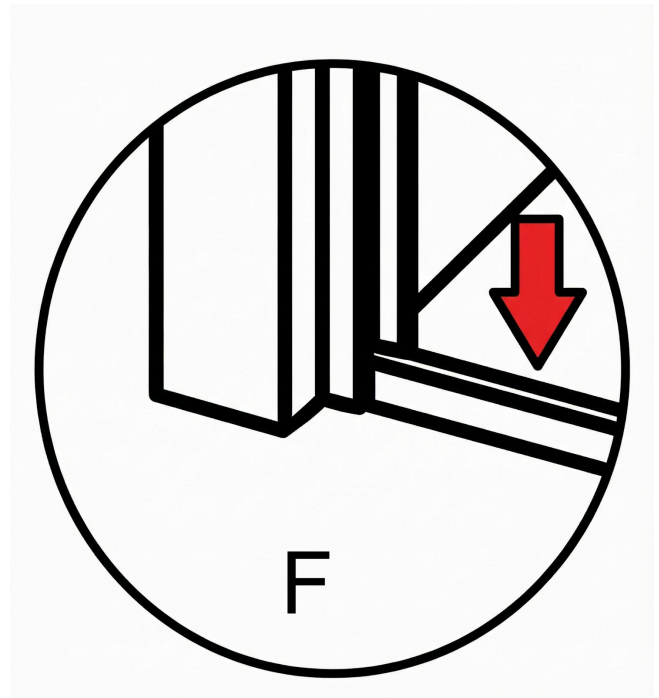
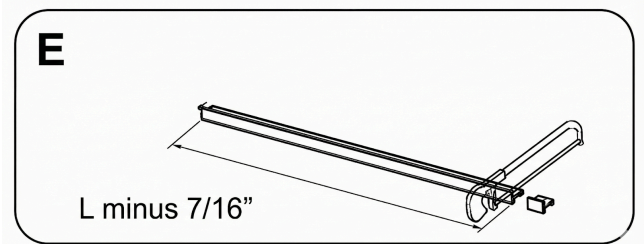
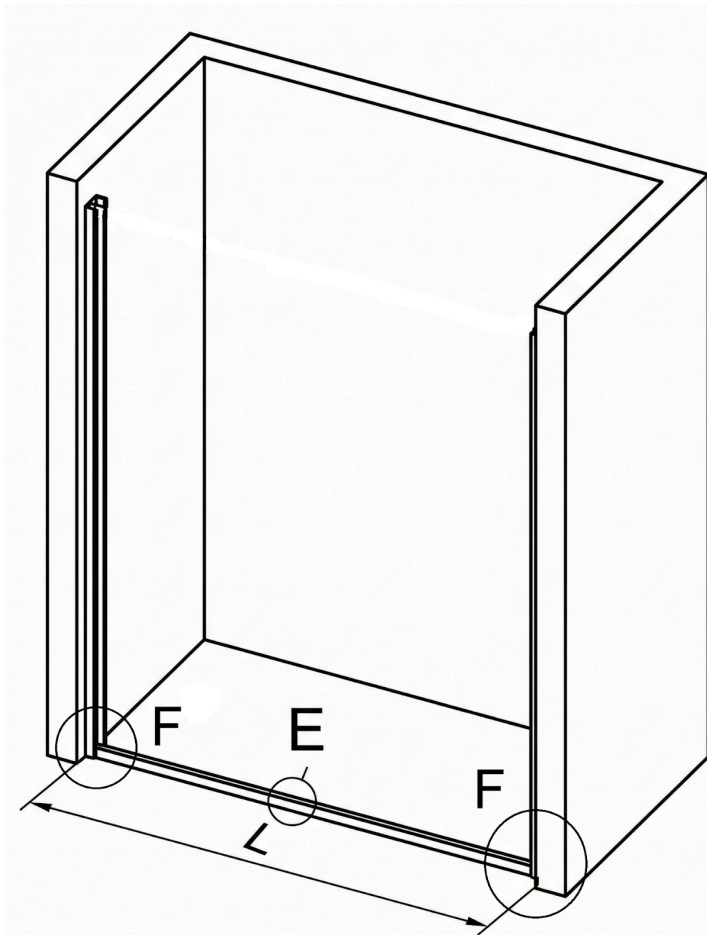

## STEP 4: INSTALL THE HEADER

- Measure and cut (if needed) to fit between the side frames (Item 3). (Shower opening width minus  $7/16''$ ).
- Drill  $3/16''$  holes on the opposite cut end as shown below. Refer to the diagram for hole size and location.
- Connect the header (Item 1) into the side frames (Item 3) using the header brackets (Item 11) and header screws (Item 13).
- Ensure the header (Item 1) is level before fully tightening.

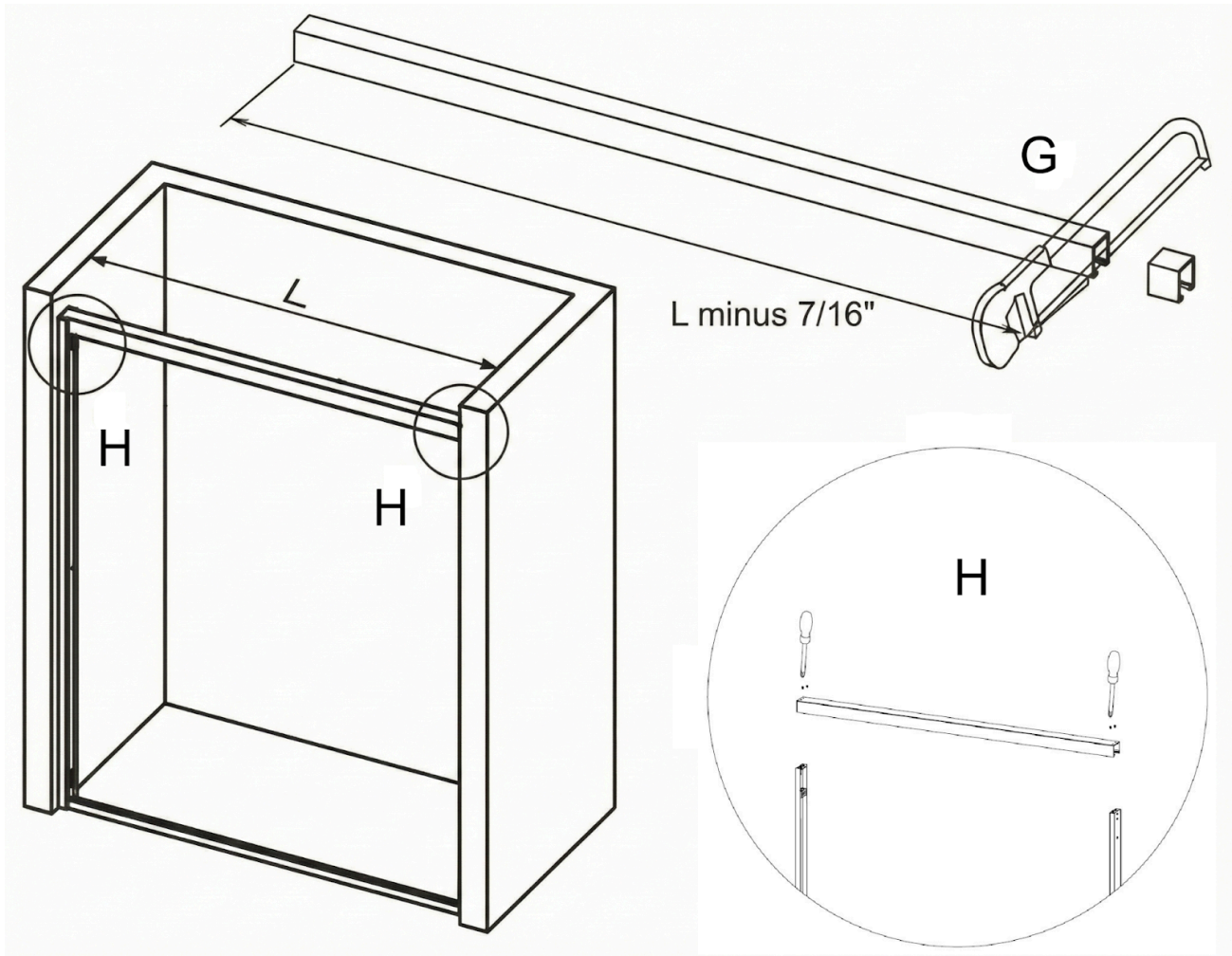

Hole size and location to drill if the header is cut on the opposite end:

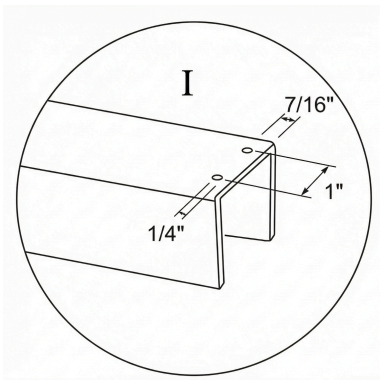

## STEP 5: ROLLER INSTALLATION

---

- Remove anti-lift clips from the roller (Item 4) assembly and set aside.
- Attach the rollers (Item 4) to the top mounting holes of the sliding door (Item 16 and 17) using the supplied tightening tools (Item 14 and Item 15).
- Verify all rollers (Item 4) are aligned and securely fastened on both sliding doors (Item 16 and 17).

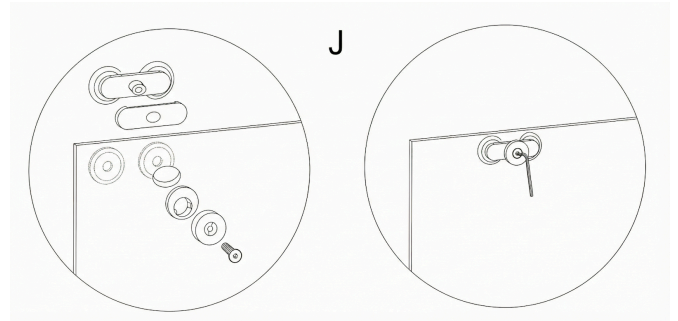
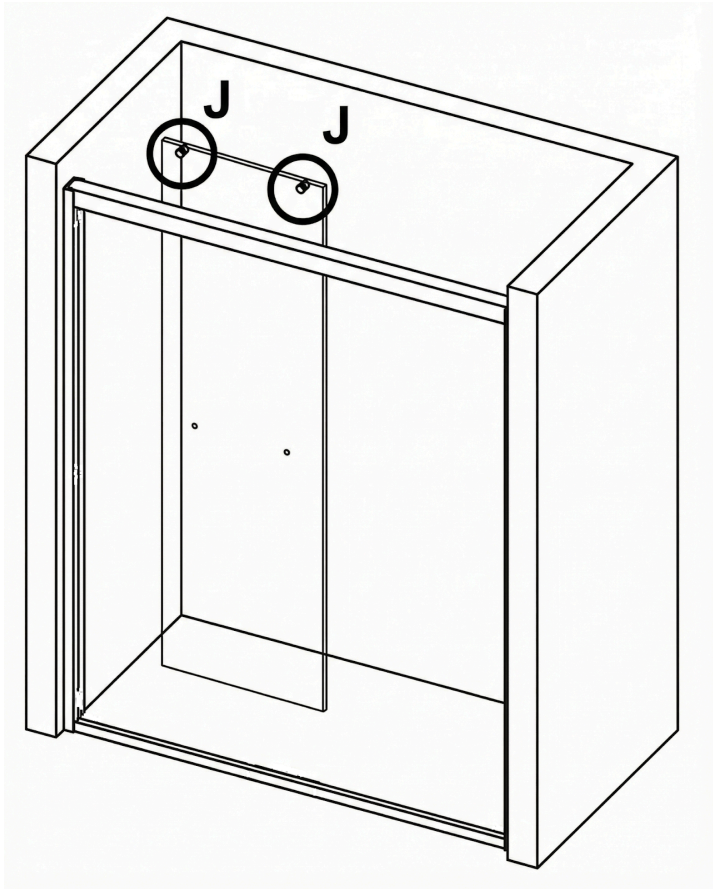

## STEP 6: SLIDING DOOR INSTALLATION

- Carefully lift the sliding door (Item 16 and Item 17) and hang the rollers (Item 4) into the header (Item 1). Position the door for the desired inner and outer panels.
- Check for smooth sliding motion.
- Adjust the roller (Item 4) if necessary for alignment.
- Attach the anti-lift to the roller assembly.

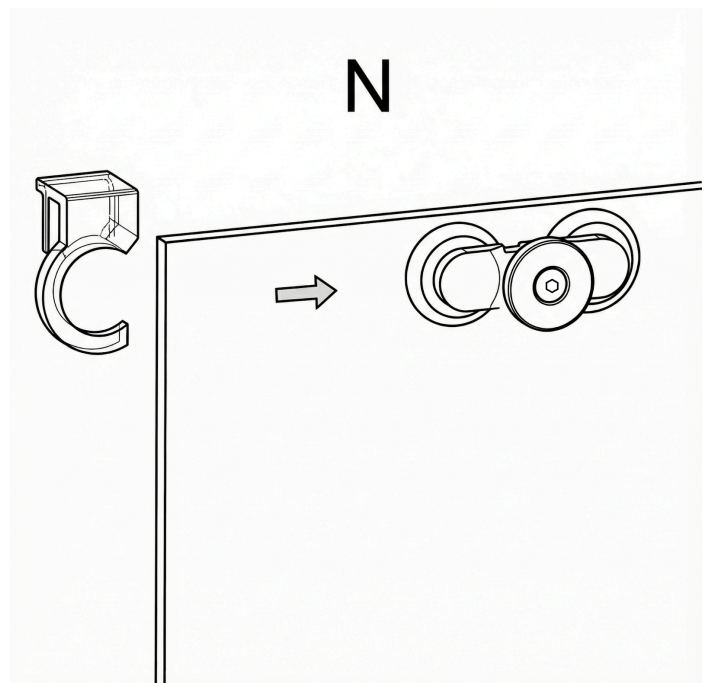
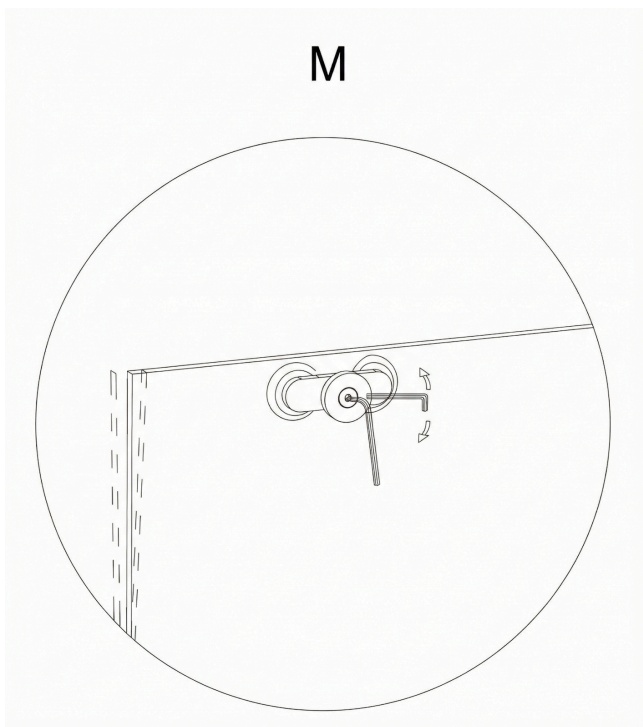
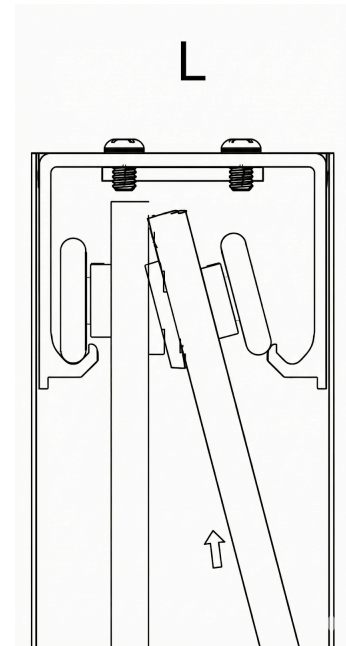
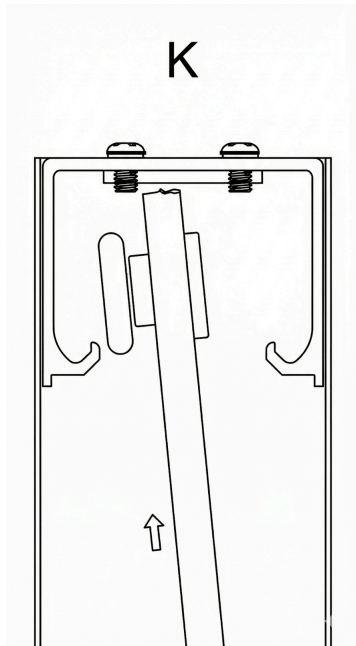

## **STEP 7: BOTTOM GUIDE INSTALLATION**

---

- Position the bottom guide (Item 6) at the bottom of the sliding doors (Item 16 and Item 17) to keep them aligned properly.
- Secure the bottom guide (Item 6) to the threshold using the bottom guide self-tapping screws (Item 12). Position it centered between the panel overlaps, left to right.
- The sliding doors (Item 16 and Item 17) should move freely through the bottom guide (Item 6).

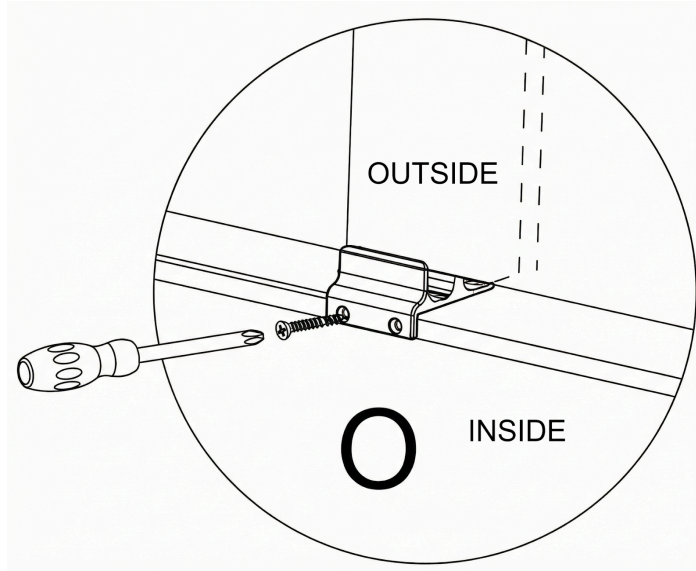

## **STEP 8: TOWEL BAR INSTALLATION**

---

- Align the towel bars (Item 5) on the sliding doors (Item 16 and Item 17).
- Secure both sides properly using the plastic washers and end caps provided with the towel bar (Item 5) assembly.
- Tighten gently and do not over-tighten against the glass.

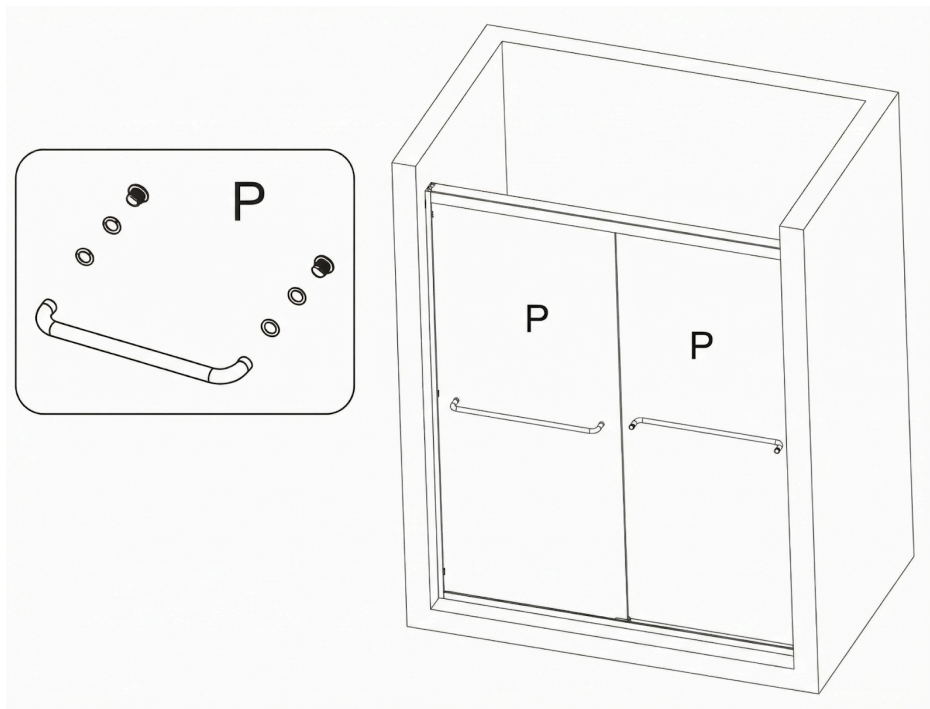

## STEP 9: FINAL ADJUSTMENTS

---

- Check that all the screws are tightened.
- Verify smooth sliding operation and proper alignment.
- Seal all inner and outer edges of the threshold (Item 2), side frames (Item 3) with clear silicone.

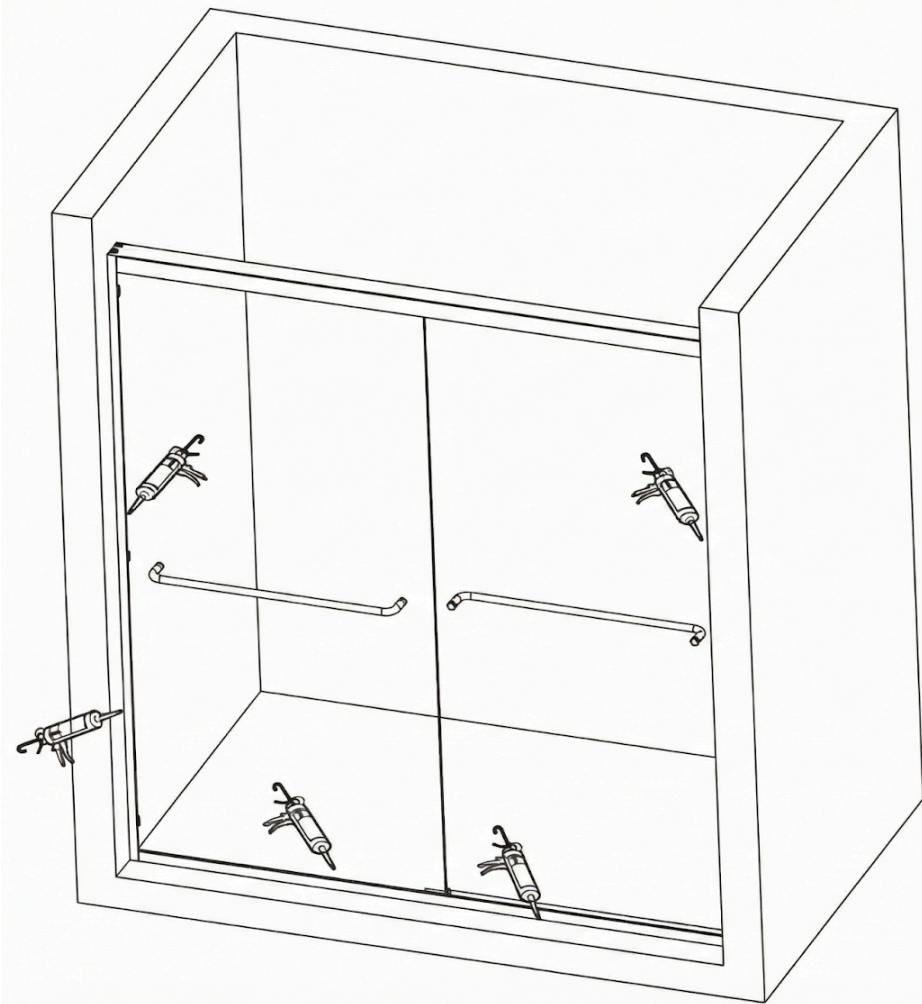

**24** HOURS

## **TERMS AND CONDITIONS**

Delivery of goods to the carrier shall constitute delivery thereof to Buyer, and thereafter such goods shall be at Buyer's risk. Any Claim by the Buyer against Modexo for shortage or damage occurring before delivery must be made within five days after receipt of the shipment. Modexo will take no responsibility for the dispatch (shipment) at the lowest cost.

## **WARRANTY**

All goods sold by Modexo are warranted to be free from defects in workmanship and material for a period of One Year from the date of purchase, which warranty is in lieu of and excludes all other warranties, representations, and conditions. Glass breakage is not covered under warranty. Modexo shall not be liable for loss, damage, or expense, directly or indirectly arising from the sale, handling, or use of the goods or from any other cause relating thereto. Modexo's liability hereunder is expressly limited to the replacement of defective goods or, at Modexo's election, to the repayment of, or crediting Buyer with an amount equal to the purchase price of any such defective goods. Any alteration in design or construction generally introduced by Modexo before dispatch of the goods shall not give the Buyer cause for complaint.

## **RETURNS AND REFUND POLICY**

You may return new, unopened items within 30 days of delivery for a full refund plus shipping charges. If the return is a result of our error (you received an incorrect or defective item, etc.), we will refund you and pay your return shipping charges. Custom orders cannot be returned.

You should expect to receive your refund within four weeks of giving your package to the return shipper; however, in many cases, you will receive a refund more quickly. This time period includes the transit time for us to receive your return from the shipper (5 to 10 business days), the time it takes us to process your return once we receive it (3 to 5 business days), and the time it takes your bank to process our refund request (5 to 10 business days).